

# LINK 2000+ Programme

## LINK 2000+ Guidance to Airborne Implementers

Cooperative Network Design

**LINK 2000+  
Guidance to Airborne  
Implementers**

**LINK 2000+ Programme**

<b>Edition</b>	<b>:</b>	<b>1.1</b>
<b>Edition Date</b>	<b>:</b>	<b>09 December 2009</b>
<b>Status</b>	<b>:</b>	<b>Released Issue</b>
<b>Class</b>	<b>:</b>	<b>LIT</b>

---

# DOCUMENT IDENTIFICATION SHEET

## DOCUMENT DESCRIPTION

### Document Title

LINK 2000+ Guidance to Airborne Implementers

### PROGRAMME REFERENCE INDEX

LINK 2000+ Programme

### EDITION :

1.1

### EDITION DATE :

09 December 2009

### Abstract

This document covers technical aspects of the implementation and use of a number of data link services, derived from the Context Management (CM) and Controller Pilot Data Link Communication (CPDLC) applications, part of the LINK 2000+ programme. Information is compiled from different locations in order to assist Airborne implementers (Aircraft Operators, Avionics Manufacturers ...) in implementing LINK 2000+ Services (DLIC, ACM, ACL and AMC) by providing guidance on the necessary steps to be followed and by sharing the lessons learned during the Pioneer Phase of the Programme.

### Keywords

**CONTACT PERSON :** Philippe Sacré

**TEL :** +352-436061506

**DIVISION :** CND

## DOCUMENT STATUS AND TYPE

STATUS	CATEGORY	CLASSIFICATION
Working Draft <input type="checkbox"/>	Executive Task <input type="checkbox"/>	General Public <input checked="" type="checkbox"/>
Draft <input type="checkbox"/>	Specialist Task <input checked="" type="checkbox"/>	CND <input type="checkbox"/>
Proposed Issue <input type="checkbox"/>	Lower Layer Task <input type="checkbox"/>	Restricted <input type="checkbox"/>
Released Issue <input checked="" type="checkbox"/>		

## ELECTRONIC BACKUP

**INTERNAL REFERENCE NAME :** LINK 2000+/LIT/Guidance to Airborne Implementers

HOST SYSTEM	MEDIA	SOFTWARE(S)
Microsoft Windows	Type : Hard disk	MS Word 2002 SP3
	Media Identification :	

## DOCUMENT CHANGE RECORD

The following table records the complete history of the successive editions of the present document.

<b>EDITION</b>	<b>DATE</b>	<b>REASON FOR CHANGE</b>	<b>SECTIONS PAGES AFFECTED</b>
0.1	1 August 2008	Document formatting under template, first internal review copy	All
0.2	Nov. 2008	Adding issues from white papers	All
0.3	Dec. 2008	Input LINK Team	All
04	Feb 2009	Input LINK Team Additional chapters on SPDU, TP4 Trimming the EEC chapter	All
0.5	March 2009	Reference check 24 bit address as "all 1" LACK and operational response	All
1.0	March 2009	Re-ordering of chapters Recommendations sections 4.1, 5.2, 5.3, 5.7 Re-wording of sections in (new) chapter 5 Change in Annex A.2 (removed paragraph) Acronym table check Submission to LIT as "draft for comments"	All
1.1	Dec. 2009	Released following comment cycle	All

## TABLE OF CONTENTS

<b>DOCUMENT IDENTIFICATION SHEET .....</b>	<b>II</b>
<b>DOCUMENT CHANGE RECORD .....</b>	<b>III</b>
<b>1. INTRODUCTION.....</b>	<b>6</b>
1.1 Background .....	6
1.2 Scope .....	6
1.3 Document organisation.....	6
1.4 Relevant documents.....	7
<b>2. DATA LINK IMPLEMENTATION.....</b>	<b>7</b>
2.1 Introduction .....	7
2.2 To-do list for airborne implementers .....	7
2.3 Functional Model .....	8
<b>3. AVIONICS ARCHITECTURE.....</b>	<b>9</b>
<b>4. IMPLEMENTATION ASPECTS.....</b>	<b>11</b>
4.1 Address information.....	11
4.2 Application message Integrity Check - AMIC.....	11
<b>5. LESSONS LEARNED FROM THE PIONEER PHASE.....</b>	<b>11</b>
5.1 CDA Message .....	12
5.2 Operational response received prior to LACK.....	12
5.3 TP4 Parameters.....	13
5.4 VDL2 Handoff Algorithm .....	13
5.5 Non-AOC operators .....	14
5.6 Reversion to POA .....	15
5.7 ATN IDRP Routing Ambiguity.....	15
5.8 Automatic CM-logon.....	16
5.9 Session Protocol Data Units (SPDU) .....	17
5.10 Timing.....	17
5.11 24-bit ICAO address configuration .....	17
<b>6. TEST AND VALIDATION SUPPORT .....</b>	<b>17</b>
6.1 Certification support.....	19

<b>7. CONCLUSION .....</b>	<b>20</b>
<b>A.1 ANNEX – ACRONYMS .....</b>	<b>21</b>
<b>A.2 ANNEX – CDA MESSAGE ISSUES .....</b>	<b>25</b>
<b>A.3 ANNEX – VDL2 HANDOFF.....</b>	<b>27</b>
<b>A.4 ANNEX – ATN ROUTING AMBIGUITY ASSOCIATED WITH VDL HANDOFF 30</b>	

## 1. INTRODUCTION

### 1.1 Background

The implementation of data link is one of the key operational improvements that will alleviate voice channel congestion. It will provide benefits to ATC efficiency, capacity and communications in order to accommodate the expected growth in air traffic demand. The EUROCONTROL LINK 2000+ Programme packages a first set of beneficial and affordable en-route controller pilot data link communication (CPDLC) services for implementation in the European Airspace using the Aeronautical Telecommunication Network and VHF Digital Link Mode 2 (ATN/VDL2).

LINK 2000+ has taken an innovative three-step approach to reap benefits faster than by waiting for the mandatory carriage:

- Pioneer phase,
- Incentives,
- Mandate (Single European Sky Data Link Services Implementing Rule – SES DLS IR)

The Pioneer phase, which started in 2003, provided all parties involved with valuable experience and many important lessons learned.

This document, together with its companion related to ground aspects, ref. [7], gathers the lessons learned in one place, hopefully offering a good starting point for new implementers of the LINK 2000+ data link services. It is targeted at a readership comprising airborne systems integrators/planners and regulators.

### 1.2 Scope

This document covers technical aspects of the implementation and use of a number of data link services, derived from the Context Management (CM) and Controller Pilot Data Link Communication (CPDLC) applications, defined by the LINK 2000+ Programme as the Data Link Baseline Services, and included in the Implementing Rule for Data Link Services ref. [1]. Information is compiled from different locations not necessarily easily accessible to the reader (unpublished white papers, emails, etc), in order to assist airborne implementers (Aircraft Operators and Avionics Manufacturers) in implementing LINK 2000+ Services (DLIC, ACM, ACL and AMC) by providing guidance on the necessary steps to be followed and by sharing the lessons learned during the Pioneer Phase of the Programme.

This document does NOT address FANS 1/A(+) implementations.

The ultimate objective is to support the use of CPDLC in a harmonised way. If required, appropriate local authorities may promulgate further specific conditions for its use.

### 1.3 Document organisation

Section 1 provides an introduction to this guidance document and defines its scope. Sections 2 and 3 provide a to-do list for airborne implementers and give an overview of the basic building blocks of the system.

Sections 4 and 5 constitute the core of the document, containing lessons learned and detailed technical implementation issues.

Sections 6 and 7 address validation, testing and certification support offered to implementers.

A set of annexes includes further details that complement the body of the document.

The list of acronyms is in Annex A.1

## 1.4 Relevant documents

The documentation supporting the LINK 2000+ programme is extensive, and below is a list of directly relevant documents. Supporting international standards referenced for LINK 2000+ are listed in [1] and [2].

- [1] DLS IR: Commission Regulation (EC) No 29/2009 of 16 January 2009 laying down requirements on data link services for the Single European Sky
- [2] EUROCONTROL Specification on Data Link Services , V 2.1, 28 January 2009
- [3] LINK 2000+: Network Planning Document (NPD), V. 3.4, 1 May 2007
- [4] LINK 2000+: Generic Requirements for a LINK 2000+ Air-Ground Communications Service Provider (ACSP), V. 1.6, December 2009
- [5] LINK 2000+: ATN Naming and Addressing Plan, V. 1.2, 19 May 2004
- [6] Addressing Database for LINK 2000+, V 1.6, November 2009
- [7] LINK 2000+: Guidance to Ground Implementers, V 1.1, 30 November, 2009
- [8] EASA AMC 20-11 "Acceptable Means of Compliance for the Approval of use of Initial Services for Air-Ground Data Link in Continental Airspace", 26/12/2007
- [9] LINK 2000+: ATC Data Link Guidance for LINK 2000+ Services, V. 5.0, 30 June 2009
- [10] LINK 2000+: Flight Crew Data Link Guidance for LINK 2000+ Services, V. 4.0, 30 June 2009

## 2. DATA LINK IMPLEMENTATION

### 2.1 Introduction

A **tutorial introduction** to the basic relevant technical concepts underlying data link is included in ref. [7].

### 2.2 To-do list for airborne implementers

Airborne implementers, specifically aircraft operators, will need to:

- equip their fleets with data link (ATN/CPDLC) capability, in terms of communication means (VHF equipment) and aircrew HMI, ,
- obtain airworthiness approval/certification - see section 6.1 for EUROCONTROL certification support
- document applicable procedures, ref. [10],

- train air crew and staff in charge of maintenance of systems:
  - appropriate training programmes for the use of ATS supported by data link communications should be organised for pilots; training programmes should be designed in accordance with guidance material defined in “Human Factors Training Manual” (ICAO Doc 9683); training programmes should be followed on a recurrent basis as determined by the State of the operator,
- obtain operational approval,
- contract one or more Air-Ground Communications Service Provider(s) (ACSP) on the basis of a service level agreement; for the use of the specified data link services in the airspace defined in the IR, an aircraft operator is free to contract with any global ACSP supporting AOC and ATS communications,
- have an Aircraft Operating Manual for each of its aircraft type, providing relevant information about the operations of ATS supported by data link services; this manual will be updated in accordance with provisions specified in Appendix 2 of ICAO Annex 6,
- specify relevant information in submitted flight plans for flights intending to use the LINK 2000+ airspace, especially the 24-bit ICAO address information in Field 18, in accordance with requirements of ref. [[2]] and Amendment S08/01 to ICAO Doc. 7030.

## 2.3 Functional Model

Figure 1 illustrates the overall LINK 2000+ functional model for the provision of data link services using the ICAO ATN. This organises the overall system into three principal domains: the Air Navigation Service Provider (ANSP) domain, the Air-Ground Communications Service Provider (ACSP) domain and the Aircraft domain. The physical architecture may be different, with functional elements lumped in common physical components.

The ANSP domain includes (among others) the Air Traffic Service Unit (ATSU) Data Processing System, an ATN End System and an ATN ground-ground router. The “**Data Processing System**” is a general term for the technical infrastructure of the ATSU where data link functionality is to be integrated. This architecture supports typical functions like Surveillance and Flight Data Processing, Operational Display, Data and Voice Communications, etc. The ANSP domain can comprise one or several ATSUs.

The ACSP domain comprises the ground system supporting the air-ground communications network, and air-ground and ground-ground ATN routers operated by the ACSP. For some ground implementers, the ANSP and ACSP domains will be under the same organisation.

The Aircraft domain includes (among others) the Aircraft Avionics System, the ATN End System, an ATN airborne router and the airborne components of the air-ground communications network.

The nomenclature used here is coherent in the LINK 2000+ programme, but can be different in documents from other sources. For instance here we will not use the term “Air Traffic Service Provider” (ATSP), although it is equivalent to the ANSP for our purposes. ATSU is an acronym also used by Airbus for its avionics architecture, which can lead to confusion. In the latter case we will always use the term “Airbus ATSU”.

As illustrated in Figure 1, this document provides guidance related to the Aircraft domain, excluding the Flight Crew Human Machine Interface, human operators and procedures. All the latter are addressed in ref. [10].

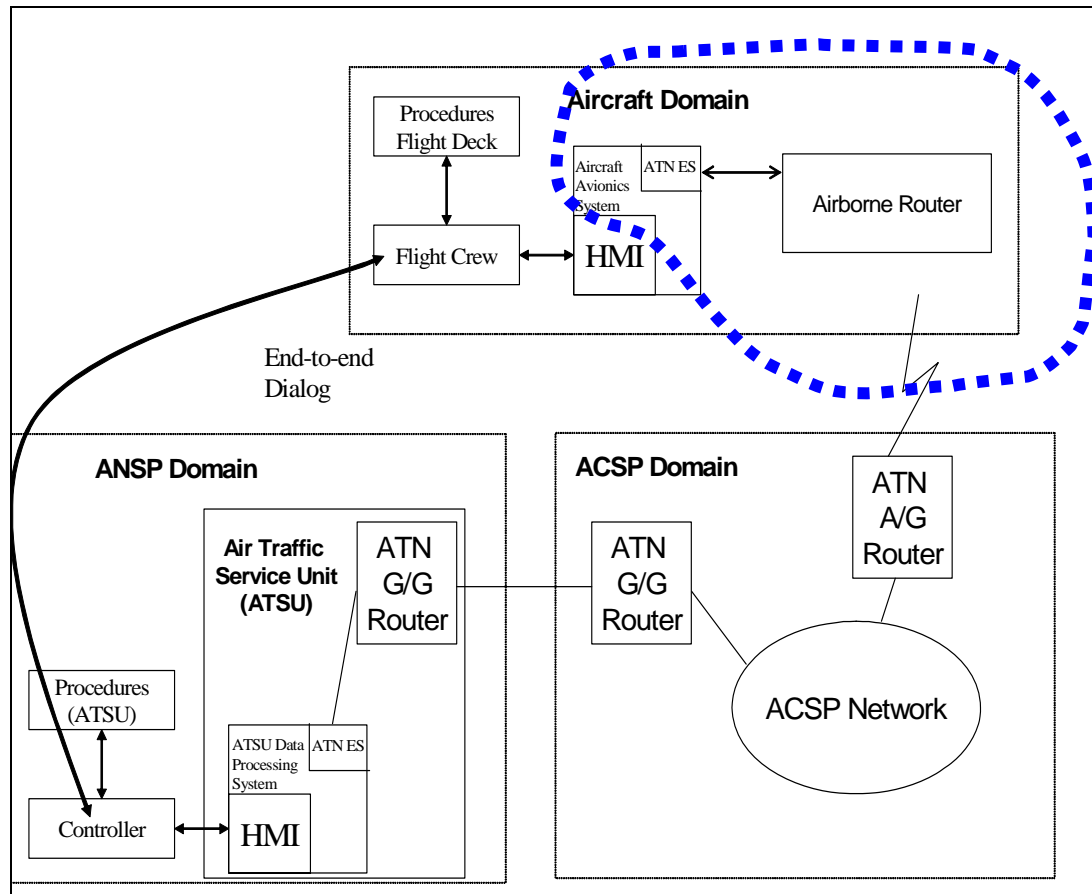

Figure 1- ATN Data Link System Functional Architecture  
Scope of this document (bold, dotted)

### 3. AVIONICS ARCHITECTURE

Two main families of avionics architecture can be encountered: federated or integrated<sup>1</sup>, and they can be both offered by vendors depending on airframe type.

A basic functional diagram based of a federated architecture is shown below. The figure is generic since units can be physically doubled.

In a federated architecture, the Communications Management Unit (CMU)/Airbus ATSU provides access to all data communications services and hosts the ATN Airborne Router and End System. One of the on-board VHF Digital Radios (VDR) is used for VDL Mode 2.

<sup>1</sup> Integrated Modular Architecture (IMA) and Distributed IMA (DIMA)

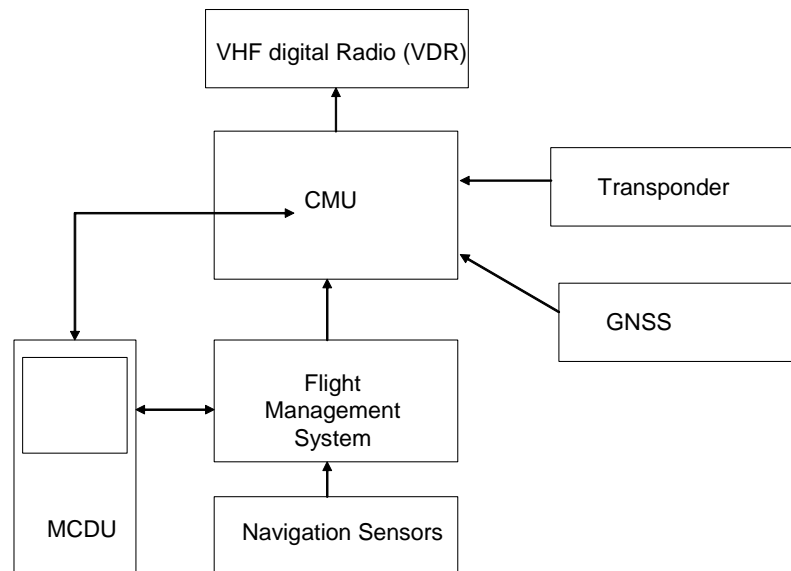

**Figure 2 - Aircraft Implementation - General Avionics Architecture**

The Flight Management System (FMS) provides information to the CMU/Airbus ATSU (Flight number, departure airport, destination airport). The Multi-function Control and Display Unit (MCDU) is used to prepare and receive preformatted messages exchanged with the ground.

*Note: For the Airbus ATSU, a separate screen, the Data Link Control and Display Unit (DCDU), is used for data link messages exchange.*

All CPDLC messages sent to the ground must be time stamped with an accuracy of better than 1 second. Therefore a Global Navigation Satellite System (GNSS) receiver is generally implemented. At the time of writing the prevalent GNSS in use is the Global Positioning System (GPS). The GPS receiver can be standalone or incorporated in a Multi Mode Receiver (MMR). If the clock of the aircraft is synchronised to the GPS, this will reduce the drift of the clock information. The clock is used to time stamp downlink CPDLC messages, and to verify the transit delay of uplink CPDLC messages.

The transponder may provide the CMU/Airbus ATSU with the 24-bit ICAO address of the aircraft. This information is needed for VDL Mode 2, CM and Protected Mode CPDLC.

## 4. IMPLEMENTATION ASPECTS

### 4.1 Address information

ATN avionics systems need to record the CM application addressing information of the Ground ATC Operational Centres involved in the LINK 2000+ programme in order to allow the air crew to perform a first CM-Logon with any of the participating centres.

LINK 2000+ maintains a document entitled “Addressing Database for LINK 2000+” ref. [6], collecting in one place the CM Application addresses of the ATC Operational Centres implementing LINK 2000+ Services. Any new ANSP implementing LINK 2000+ Services should declare their Context Management application address information for inclusion in the above mentioned document.

***It is recommended that avionics implementers provide Airlines with a flexible way:***

- ***to modify an existing addressing database themselves, or***
- ***to download an updated database.***

### 4.2 Application message Integrity Check - AMIC

As explained in the tutorial section of ref. [7], the default CPDLC application is actually the “Protected Mode” (PM) version, where an Application Message Integrity Check (AMIC) is performed on each message in order to meet Safety Requirements on message mis-delivery and integrity.

The AMIC allows verifying that:

- a CPDLC message has been delivered to the right destination,
- a message has been sent by the intended source.

At both ends of the message exchange, the locally computed AMIC, including *24-bit ICAO address, Aircraft flight ID, Ground Facility Designator (GFD) and the message content* is compared to the AMIC conveyed in the received message.

*Note: The terminology used in this document is “Aircraft flight ID”, and represents the Item 7 of the ICAO Flight Plan (e.g. DLH123P).*

**It is important to stress that on the reception side, the local AMIC must be computed with locally known values of the 24-bit ICAO address, Aircraft flight ID and GFD.**

*Note: When the aircraft does not have a CDA connection, the GFD value used to compute the local AMIC will have to be taken from the uplink CPDLC-Start message.*

## 5. LESSONS LEARNED FROM THE PIONEER PHASE

This section contains recommendations resulting from lessons learned during the Pioneer phase, including those compiled from white papers. Detailed content of the white papers is included in annexes.

## 5.1 CDA Message

When an aircraft recognises that a ground unit has become the Current Data Authority (CDA), the aircraft is required to send a CDA message to allow CPDLC exchanges to proceed. As explained in Annex A.2, it may occur that a CDA message (Downlink Message DM99) sent by an aircraft is not received in time due to unexpected network delays.

In such a situation the the CDA message may be answered with an ERROR message, in which case it would NOT trigger the mechanism on the ground side which allows the aircraft to be assumed by the controller in order to proceed with data link exchanges.

In the absence of a recovery procedure, either on the ground side or on the air side, both sides may face a situation where a CPDLC connection is established between them but ATC exchanges are not possible.

It may occur as well that, even if a CDA message has been Logically Acknowledged (LACK) by the ground as expected, the LACK may not be received in time due to unexpected network delays on the uplink path.

**When the LACK response to DM99 is not received in time (i.e. before the aircraft timer expiration), it is recommended that:**

**a- the aircraft re-sends the DM99 again (up to maximum 2 more times if needed),**

**b- if a positive response for the DM99 is still not received on the 3<sup>rd</sup> attempt, then the aircraft should generate a user abort ('current-data-authority-abort') to terminate the link,**

*Note: Interoperability standards being developed for future generation data link systems may impose requirements on the ground systems regarding the latency check on system generated messages (i.e. DM99). However, the present document is focusing on LINK2000+ lessons learned from the pioneer phase.*

## 5.2 Operational response received prior to LACK

ICAO ATN SARPs do not specify the action to be taken in the event that, following a CPDLC message requesting a LACK, an operational response is received prior to the LACK. Such a scenario would not normally be expected to occur, since the Transport layer should ensure that the sequence of messages is preserved. However, certain ground architectures may not guarantee to preserve strict message sequence between the Application and Transport layers, and in such cases, it is conceivable that the operational response might overtake the LACK, albeit with very low probability.

For overall system robustness and in order to clarify a situation where the SARPS do not provide specific guidance, it is **recommended that if a corresponding operational response is received prior to the expected LACK, the CPDLC transaction should proceed as if the LACK had been received. The LACK received after the associated operational response should be discarded.**

**Loss of the CPDLC connection (e.g. by issuing a user-abort) in these circumstances should be avoided.**

### 5.3 TP4 Parameters

The TP4 protocol includes a number of parameters, for which some appropriate settings have been recommended in the EUROCONTROL Specification on DLS (ref. [2]) Table B-6.

We re-emphasize the need to set the TP4 parameters as recommended in the EUROCONTROL above mentioned document.

Nevertheless, during the LINK 2000+ Pioneer phase, it has been noticed that some airborne and ground implementations have not applied the TP4 settings as recommended in the EUROCONTROL Specification on DLS - this is particularly the case for the Window Timer (W).

The Window Timer may be dynamically computed on a per TP4 connection basis. Dynamic computation taking into account the Remote Inactivity Timer (conveyed in TP4 Connect Request/Connect Confirm) is suggested in Doc. 9705 Ed. 2, Table 5.5-1.

However, when such a computation is used, certain erroneous configurations may lead to a period of inactivity on the TP4 connection (TP4 ACK not sent/TP4 ACK not received) when there are no application exchanges. This eventually leads to the expiry of the local TP4 Inactivity Timer and generation of an application provider abort.

**In order to improve robustness of the TP4 protocol under such conditions, the following is recommended:**

- a) **The formula suggested in the Doc. 9705 (Note 5 of Table 5.5-1) suffers most likely from an editorial omission of a subscript, and the 'l' should be interpreted as referring to the Remote Inactivity Time.**
- b) **In the Doc. 9705 formula, the Window Timer Offset should be set to a value slightly greater than 50% of the Remote Inactivity Time, to ensure that W expires at least twice prior to expiry of the Remote Inactivity Timer.**
- c) **The value of W resulting from the Doc. 9705 formula should be constrained by a minimum and maximum value of W:**
  - **The minimum value ensures robust behaviour if the computation returns a –ve value, and also avoids saturation of the ATN/VDL network in the event that an exceptionally short value of the Remote Inactivity Timer is erroneously configured.**
  - **For aircraft in the LINK 2000+ environment, a minimum W value of 1 minute and a maximum W value of 2 min are recommended.**
  - **It may be necessary to re-configure the minimum value in order to accommodate future more demanding operational environments such as TMAs.**

### 5.4 VDL2 Handoff Algorithm

VDL Mode 2 SARPs, together with ARINC 631, define protocols and XID exchanges to effect handoff from one VDL Ground Station (VGS) to another. However, the exact criteria for

initiating handoff are not described by these documents and remain under the discretion of implementers.

As explained in more details in Annex A.3, EUROCONTROL has performed many hours of flight testing of ATN/VDL Mode 2, during which extensive observations have been recorded on link and handoff performance.

It is not EUROCONTROL's intention to propose specific handoff algorithms for implementers, but to offer general guidance based on observations made during such flight testing.

Implementers should design their handoff algorithms recognising the following:

- d) Handoff algorithms should seek to avoid maintaining an Aviation VHF Link Control (AVLC) link under conditions where there is a significantly increased risk of AVLC re-tries.
- e) The risk of AVLC re-tries appears to be significantly increased at Signal Quality Parameters (SQP) less than 2.
- f) Handoff algorithms should avoid generating handoffs in rapid succession, under conditions of rapid changes in SQP and/or short term nulls from individual VGSs.

For example, it may be advantageous for the aircraft to take into account the long term trend of SQP for each VGS recorded in the Peer Entity Contact Table (PECT). The trend would require a high degree of smoothing to reduce the impact of rapid short term fluctuations. With such information available, handoff could be initiated from a station with falling SQP to one with rising SQP, whenever the SQP from the candidate VGS exceeds that of the current SQP by a pre-determined margin. When the current SQP falls below 2, the criteria may be relaxed, to initiate handoff to any station with superior SQP, giving precedence to a VGS whose SQP is increasing.

Additionally, the handoff algorithm may take account of additional information on the quality of the AVLC link, such as the AVLC re-try rate, or the level of error correction applied (not currently available outside of the VDR) which may complement SQP in determining when to initiate handoff.

## 5.5 Non-AOC operators

Non-AOC operators will need to be able to perform CPDLC with ANSPs. In accordance with established industry principles, such operators will expect ATS communications to be carried without charge to themselves.

The LINK 2000+ NPD, ref. [3], envisages a model of competitive VDL service provision in which each ANSP contracts with a Primary ACSP, that is contractually bound to provide communication service supporting ATSC with non-AOC operators without charge to the operator. However, no such obligation exists on any Alternative ACSPs covering the same airspace.

The Primary ACSP may in principle change when an aircraft crosses from the airspace of one ANSP to another. However, no technical mechanism exists in current VDL standards to identify which ACSP is the Primary provider in any given airspace. Accordingly, non-AOC

avionics would not know when to switch to a different Primary ACSP without maintaining a complex database of airspace boundaries and providers.

LINK2000+ is presently pursuing discussion with ACSPs to identify an Institutional solution whereby non-AOC operators will be able to perform ATSC free of charge, without being required to switch to a new ACSP when the Primary provider changes at an airspace boundary.

*Note: Forthcoming decisions will be reflected in future editions of this document or other sources.*

## 5.6 Reversion to POA

If VDL coverage is temporarily lost, avionics generally revert to POA (Plain-Old-ACARS, also called VDL Mode A), and eventually return to VDL when adequate coverage is re-gained. However, the effect of reversion to POA on the ATN stack varies between avionics vendors. Some avionics require the CPDLC connection and ATN stack to be re-established. However CPDLC is ground initiated and the ground system may not automatically re-establish a lost CPDLC connection.

A consistent avionics strategy is needed following reversion to POA.

In order to avoid permanently losing CPDLC due to any temporary loss of VDL coverage, it is proposed to maintain the original CPDLC and transport connections on the aircraft.

**The recommendation is thus that:**

- **following a POA reversion, the CMU should never leave the CPDLC enabled state before expiration of the TP4 inactivity timer,**
- **a local system management procedure should prevent the pilot initiating a CPDLC downlink while no ATN link exists (i.e. no air/ground link exists to carry messages) to transfer messages,**
- **upon restoration of ATN/VDL connectivity prior to expiry of the TP4 inactivity timer, the CPDLC connection should continue to operate,**
- **no automatic CM-logon should be sent.**

## 5.7 ATN IDRP Routing Ambiguity

Under various scenarios, ATN IDRP Routing Ambiguity may arise following VDL Handoff, leading either to use of an inappropriate Route to the aircraft, or else in the worst cases to maintenance of a 'black-hole' Route that is incapable of reaching the aircraft

In the case of uplinks, the problem may be effectively mitigated by measures implemented by the ACSP. The Generic ACSP Requirements document [4] requires such measures to be implemented.

In the avionics, additional measures are also necessary to ensure that following a VDL handoff involving a change of A/G Router, downlink Protocol Data Units (PDUs) are transferred via the new IDRP route in preference to the previous route via the old VGS. ICAO ATN SARPs do not specifically require this behaviour, and without such functionality, the

aircraft may continue to transfer messages over the previous VDL connection, until expiry of the aircraft TG5 timer, even after a successful handoff.

This behaviour is undesirable, since it may result in packets being routed over a poor quality link when a better link is already available. This may not only add overhead to the RF channel due to excessive AVLC re-tries, but may also in extremis lead to loss of packets at the network layer, necessitating Transport layer re-tries, and significantly elevated downlink delays.

Anomalous behaviour has also been observed when performing forced transitions between different service providers. When establishing a connection with a new ACSP, industry standards permit the avionics to retain the connection with the previous ACSP in accordance with airline preferences. In this event, IDRPs via both providers may exist with equal merit, and the avionics cannot assume that uplink traffic will necessarily be routed via the preferred provider. In order to ensure that ATN traffic is routed via the preferred provider, the avionics must take further steps. If the connection via the old provider is required only to support non-ATN services, then the avionics may simply close the VDL 8208 Switched Virtual Circuit (SVC) via the old provider, once IDRPs have been established via the preferred ACSP.

More details are provided in Annex A.4.

**Recommendations to overcome these issues are as follows:**

- **avionics should assert a local preference for the IDRPs route via the new VGS, following a VDL handoff involving a change of A/G Router,**
- **when connections exist with more than one provider at the same time, avionics should implement measures to ensure that ATN traffic is routed via the preferred provider, normally by disconnecting the SVC to the non-preferred provider as soon as an IDRPs Adjacency has been established via the new provider and routes to the ground have been received.**

## **5.8 Automatic CM-logon**

In case of power transients on aircraft leading to loss of connectivity, avionics designers may choose to perform an automatically generated CM-logon. In the simplest case, such a CM-logon might be sent to the ground system to which the last manual CM-logon was addressed. However, one or more transfers may have occurred since then, in which case this would not be the appropriate strategy.

**When a vendor elects to implement automatic CM-logon, it is recommended that:**

- **the CMU should address an automatic CM-logon to the appropriate centre by reference to the last CPDLC connection established, i.e. the last CDA,**
- **when the CM-logon response is positive, the CMU reverts to/enters the CPDLC enabled state.**

## 5.9 Session Protocol Data Units (SPDU)

Short Refuse Session Protocol Data Units (SRF SPDUs) are used in the CM-Logon response process. If an avionics implementation does not support the reception of a given encoding notified by the ground system, interoperability problems will arise. Although the ref. [2], section B.2.4.3 recommendation is to notify E3 instead of E2, all cases can occur.

**Avionics implementers shall thus be able to support the reception of any of the SRF SPDUs, considering the recommendation added in ref. [2], section B.2.4.3.**

*Note: 'Pioneer' aircraft deviating from this requirement may be accommodated by pioneer ground systems (see ref. [7]) only until the DLS IR mandate enters into force.*

## 5.10 Timing

If the avionics fail to acquire the correct UTC time, CPDLC messages may be rejected due to failure to validate the time stamp inserted by the sender of the message.

This unfortunate situation has been observed in the Pioneer Phase, due to the persistent failure of some on-board sensors (GNSS) to acquire the correct UTC time. The failure to acquire time correctly has not been apparent either to the flight or maintenance crews, thus preventing prompt correction.

An example of a technique that might be used to identify such a condition would be to compare alternative time sources available to the avionics, and to flag any gross discrepancies indicating a potential failure of a trusted source.

**Avionics vendors are recommended to take practical measures to identify any failure to acquire the correct UTC time, so as to allow prompt resolution, and avoid confusion to flight crews.**

## 5.11 24-bit ICAO address configuration

Unfortunate situations have been noticed where the airborne 24-bit ICAO address is, or ends up being, wrongly configured as 'all 1s'. This 24-bit address is reserved by ICAO for VDL broadcasts, and transmissions carrying this address erroneously risk causing significant disruption to the VDL system.

**The recommendation is that avionics systems implement a functionality to ensure that 24-bit ICAO addresses configured as "all 1s" are detected and corrected in a timely manner, e.g. through automatic 24-bit ICAO address configuration check and generation of warnings to the air crew when errors are detected.**

## 6. TEST AND VALIDATION SUPPORT

Airborne implementers can benefit from services provided by the LINK 2000+ data link Test Facility located at the EUROCONTROL Experimental Center (EEC) in Brétigny-sur-Orge near Paris.

The main objective of the LINK 2000+ Test Facility is to support the validation of operational CPDLC services and ATN/VDL Mode 2 infrastructure for both air and ground implementations before they are approved in an ATC operational environment.

The LINK 2000+ data link Test Facility provides an interoperability testing platform for the LINK 2000+ baseline services and offers:

- support to Avionics suppliers on CPDLC/ATN/VDL Mode 2 interoperability testing,
- support to Airlines in training, familiarisation, and support to certification (section 6.1),
- support to ANSP implementations on CPDLC/ATN interoperability testing,
- support to Air-Ground Communication Service Providers (ACSPs) in testing of LINK 2000+ ATN/VDL Mode 2 Air-Ground and Ground-Ground infrastructure.

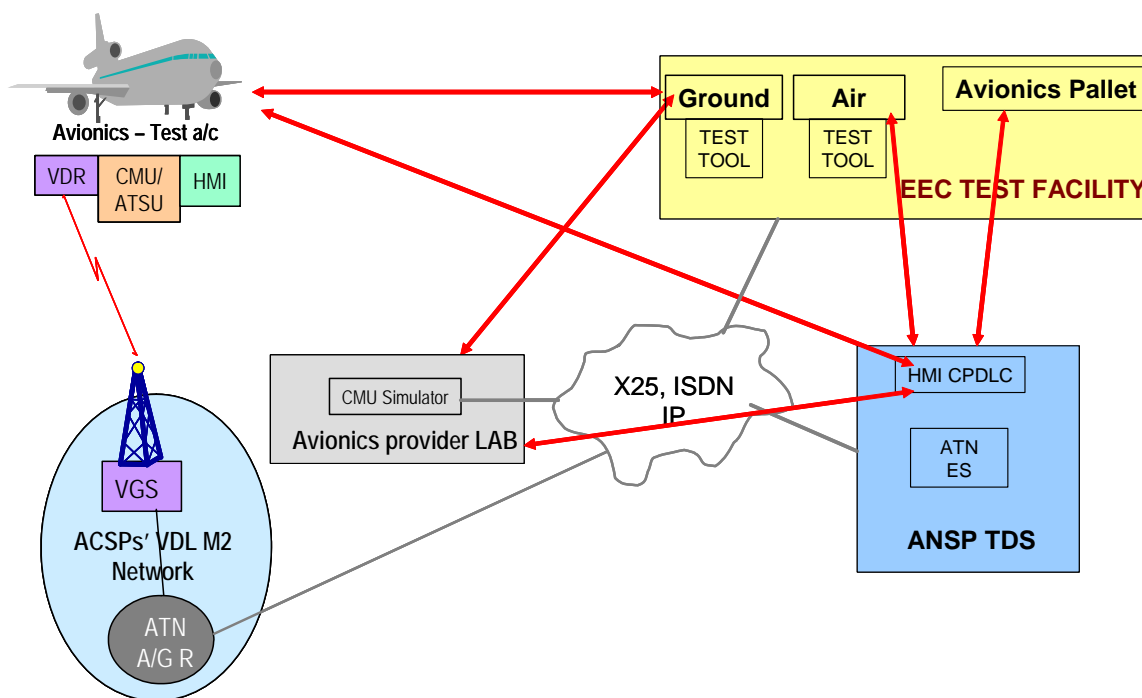

Figure 4 – Test and validation context

Validation and interoperability testing activities with an avionics vendor may follow the sequenced approach described below:

- The avionics partner defines an Interoperability Test plan at CM/CPDLC level for his own system. The avionic partner may use as a guidance document the Avionics Generic Interoperability Test Plan document published by EUROCONTROL (see [http://www.eurocontrol.int/link2000/public/standard\\_page/airlines\\_validation.html](http://www.eurocontrol.int/link2000/public/standard_page/airlines_validation.html))
- In a first step the avionics is evaluated in a “LAB-to-LAB” configuration to verify application level interoperability; the validation is performed:

- against the Test Facility Ground Test Tool(s) (TT). Evaluation includes interoperability testing defined by Avionics, as well as extra test cases such as:
  - Error test cases: LACK not sent back, invalid Message Identifier or Message Reference included in a message, unsupported message sent to the air implementation,
  - Exercise of continuous flow of erroneous messages to test the robustness of the remote air system (“tuning test”);
- against available ANSP implementation in order to identify potential interoperability issues at an early stage.
- In a second step, if possible, an avionics pallet is installed at the EEC. This pallet is connected via coaxial cable to the Air Ground Test Station (AGTS):
  - validation is performed against the Test Facility Ground Test Tool(s):
    - aircraft VDL Mode 2 handoff behaviour is checked while exercising tuning tests from the Ground Test tool with a configurable period (10 to 3 second interval).
    - the avionics CM/CPDLC Interoperability Test plan is run at EEC as well as the extra test cases mentioned above.
  - interoperability testing may be performed against available ANSP ground implementation.
- In a third step the avionics pallet undergoes flight testing aboard an appropriately equipped aircraft such as the NLR Citation currently employed by the LINK 2000+ Programme (NLR is the “Nationaal Lucht en Ruimtevaartlaboratorium”, the Dutch National Aerospace Laboratory). The objective of such a step is to check the aircraft behaviour in an operational VDL Mode 2 environment.

## 6.1 Certification support

Avionics manufacturers and aircraft operators are responsible for obtaining airworthiness approval/certification and for demonstrating the compliance of their systems with relevant regulations and applicable standards prior to their putting into service, even in a cases of operational trials operation, refs. [8], [10].

EUROCONTROL does not grant Certificates or Approvals of any description but will provide guidance on the processes.

The LINK Test Facility provides an inter-operability testing platform for equipment compliant with the Datalink Services Implementing Rule [ref. [1] ] and the Eurocontrol Specification on Data Link Services [ref. [2] ]. The Test Facility is not a formally qualified test tool but high level requirements have been documented and traced to the LINK Test Facility.

LINK 2000+ Test Facility may provide inter-operability testing support for airworthiness approval/certification tests required (in flight or on the ground). The output consists of a Report containing the test results on an “as is” basis. The report and the test results may then be used in support of the official processes/application by the implementers/applicant, provided that EUROCONTROL is informed of the intended use and the implementer/applicant take full responsibility for the use of the results.

## **7. CONCLUSION**

With the approval of the Data Link Services Implementing Rule at the end of 2008, implementation is under way and it is expected that material compiled in this document will be of value to stakeholders concerned by this European Regulation.

Future editions of this document will reflect on-going developments.

## A.1 ANNEX – Acronyms

This table contains acronyms for the airborne and ground implementers guidance documents.

A/C	Aircraft
A/L	Airline
ACARS	Aircraft Communications Addressing and Reporting System
ACC	Area Control Centre
ACK	Acknowledgement
ACL	ATC Clearances service
ACM	ATC Communications Management service
ACSP	Air-Ground Communications Service Provider
ADS	Automatic Dependent Surveillance
AEEC	Airlines Electronic Engineering Committee
A/G	Air/Ground
AGDL	Air Ground Data Link
AGTS	Air Ground Test Station (at EEC Brétigny)
AIC/P	Aeronautical Information Circular/Publication
AMC	ATC Microphone Check service
AMC	Acceptable Means of Compliance
AMIC	Application Message Integrity Check
ANSP	Air Navigation Service Provider
AOA	ACARS Over AVLC
AOC	Airline Operations Communications / Centre
ASE	Application Service Element
ASN.1	Abstract Syntax Notation 1
ATC	Air Traffic Control
ATM	Air Traffic Management
ATN	Aeronautical Telecommunication Network
ATS	Air Traffic Services
ATSC	Air Traffic Services Communications
ATSP	Air Traffic Services Provider
ATSU	Air Traffic Services Unit
AVLC	Aviation VHF Link Control
BER	ASN.1 Basic Encoding Rules

BIS	Boundary Intermediate System
CDA	Current Data Authority
CFMU	Central Flow Management Unit
CLNP	Connectionless Network Protocol
CM	Context Management
CMU	Communications Management Unit
CNS	Communications, Navigation, Surveillance
COTR	Coordination and Transfer
CPDLC	Controller Pilot Data Link Communication
CWP	Controller Working Position
DCDU	Data Link Control and Display Unit
DL-FEP	Data Link Front End Processor
DLIC	Data Link Initiation Capability service
DLS	Data Link Services
DM	Downlink Message
EATMN	European Air Traffic Management Network
EEC	EUROCONTROL Experimental Centre
ES	End System
ETSO	European Technical Standard Order
EUROCAE	European Organisation for Civil Aviation Equipment
FANS	Future Air Navigation Services
FDPS	Flight Data Processing System
FEP	Front End Processor
FIS	Flight Information Service
FMS/FMC	Flight management System/Computer
FMTP	Flight Message Transfer Protocol
FPL	Flight Plan
G/G	Ground/Ground
GFD	Ground Facility Designator
GNSS	Global Navigation Satellite System
GPS	Global Positioning System
GSIF	Ground Station Identification Frame
HMI	Human-Machine Interface
ICAO	International Civil Aviation Organisation
ICS	ATN Internet Communications Service

ID	Identification
IDRP	Inter-Domain Routing Protocol
IEC	International Electro technical Commission
IFPS	Initial Flight Plant Processing System
IR	Implementing Rule
IS	Intermediate System
ISO	International Organisation for Standardisation
ITU-T	International Telecommunication Union – Standardisation Sector (formerly <u>CCITT</u> : Comité consultatif international téléphonique et télégraphique)
LACK	Logical Acknowledgement
LAN	Local Area Network
LISAT	LINK 2000+ Statistics Analysis and Reporting Tool
LIT	LINK 2000+ Integration Team
LOF	Logon Forwarding (OLDI Message)
MCDU	Multi-function Control and Display Unit
MMR	Multi Mode Receiver
MOC	Means of Compliance
MsgID	Message Identifier (CPDLC)
MsgRef	Message Reference (CPDLC)
MUAC	EUROCONTROL Maastricht Upper Area Control Center
NAN	Next Authority Notified (OLDI Message)
NDA	Next Data Authority
NPD	LINK 2000+ Network Planning Document
NSAP	Network Service Access Point
NSEL	Network Selector
NTP	Network Time Protocol
OFG	LINK 2000+ Operational Focus Group
OLDI	On-Line Data Interchange
PDR	Proposed Defect Report (to ICAO Documents)
PDU	Protocol Data Unit
PECT	Peer Entity Contact Table
PER	ASN.1 Packed Encoding Rules
PISC	Pre-Implementation Safety Case
PM-CPDLC	Protected Mode CPDLC
POA	Plain Old ACARS (VDL Mode A)

QoS	Quality of Service
RF	Radio Frequency
SARPs	ICAO Standards and Recommended Practices
SBY	Stand-By, Back-up System
SC	Safety Case
SES	Single European Sky
SESAR	Single European Sky AT Research
SNDCF	Sub-Network Dependent Convergence Function
SPDR	Specification Defect Report
SPDU	Session Protocol Data Unit
SPR	Safety and Performance Requirements
SQP	Signal Quality Parameter
SRF	Short Refuse
SVC	Switched Virtual Circuit
SWAL	Software Assurance Level
TCP/IP	Transport Control Protocol / Internet Protocol
TDS	Test and Development System
TP4	Transport Protocol Class 4
TP4 CC/CR	TP4 Connect Confirm/Connect Request
TPDU	Transport PDU
TSAP	Transport Service Access Point
TSEL	Transport Selector
TT	Test Tool
ULCS	ATN Upper Layer Communications Service
UM	Uplink Message
UTC	Universal Time Coordinate
VDL	Very High Frequency Digital Link
VDL2	VDL Mode 2
VDR	VHF Data/Digital Radio
VGS	VHF Ground Station
VHF	Very High Frequency
VRB	Voice Read Back
XID	eXchange identification (ID) (frame)
XML	eXtensible Markup Language

## **A.2 ANNEX – CDA Message Issues**

This annex contains the complete text of the eponymous white paper, reproduced here for the reader's convenience.

### **Introduction**

This is the description of an abnormal situation where a DM99 CDA message is not received/LACK'ed in due time; this situation has already been observed during Maastricht CPDLC operations.

Some process implementation recommendations are given for the LINK 2000+ Baseline, based on the earlier PETAL2 Baseline, in order to increase chance of recovery from the aircraft perspective and to avoid some air/ground asynchronous situations such an unfortunate event can lead to.

### **Description of the situation**

It may occur that a CDA message (DM99) sent by an aircraft to the ground center becoming the Current Data Authority is not received in time due to unexpected network delays.

In such a situation the CDA message will be answered with an ERROR message and it will therefore NOT trigger the mechanism on the ground side which allows the aircraft to be assumed by the controller in order to go on with data link exchanges.

In case no mechanism has been implemented, either on the ground side or on the air side, both sides may face a situation where a CPDLC connection is established between them but ATC exchanges are not possible.

It may occur as well that, even if a CDA message has been LACK'ed by the ground as expected, the LACK may not be received in time due to unexpected network delays on uplink.

### **Issue raised in the context of PETAL2**

This problem had already been raised in the context of PETAL2 programme and a Specification Defect Report (SPDR) SPDR\_32\_013 was integrated in the PETAL2 baseline to solve the issue; unfortunately this SPDR was not retained in the LINK 2000+ baseline.

### **Description of PETAL2 SPDR SPDR\_32\_013**

In case a LACK is not received in response to DM99, the SPDR\_32\_013 content is reading:

- a- The aircraft shall re-try by sending the DM99 again (up to 2 more times if needed).
- b- If a positive response for the DM99 is still not received on the 3rd attempt, then the aircraft shall generate a user abort (current-data-authority-abort) to terminate the link.
- c- The ACL service shall NOT be inhibited on the air side during the retries.

### **Analysis**

If network delays are faced at some point on the previous ones, requirement a) leaves some chance to the second or third CDA message to be processed correctly on the ground.

Requirement b) avoids that a CPDLC connection remain in place with a Ground Facility Designator (GFD) being mentioned as CDA on the CMU - when no LACK was received as expected because the CDA was delayed - thus leading to inconsistency between air and ground sides.

Comment on Requirement c): DL ACL requests will nevertheless not be processed on the ground until the aircraft has been assumed (i.e: until UM 183, CURRENT ATC UNIT xxxx is sent).

Needless to say that both a) and b) features have some good merit for implementation.

## **Conclusion**

Such a delayed CDA message situation has been faced and analyzed in summer 2007 in Maastricht UAC; potential other cases may have already been faced but were not examined.

In the specific case which has been studied, the initial CDA message was answered with an uplink ERROR message. Fortunately the involved aircraft was equipped with avionics featuring a "retry mechanism" implementation, and the second transmitted CDA message, which was received in due time (and lacked as expected), allowed to trigger further data link exchanges from the ground side perspective.

Therefore considering the above description, it is recommended to implement at least the first two features of PETAL2 SPDR\_32\_013.

This does not prevent any additional mechanism to be implemented on the ground side for additional overall system robustness.

## **A.3 ANNEX – VDL2 HANDOFF**

This annex contains the complete text of the eponymous white paper, reproduced here for the reader's convenience.

### **Introduction**

VDL Mode 2 SARPs together with ARINC 631 define protocols and XID exchanges to effect handoff from one VGS to another. However, the exact criteria for initiating handoff are not described by these documents and remain under the discretion of implementers.

In the course of validating systems for operation within LINK 2000+, EUROCONTROL has performed in the region of 40 hours of flight testing of ATN/VDL Mode 2, during which extensive observations have been recorded on link performance. This annex highlights lessons learned during the course of this testing, that implementers may wish to take into account when designing handoff algorithms.

In addition, EUROCONTROL has also undertaken analysis of handoff behaviour, based on a simulated environment.

### **HANDOFF PROCEDURES**

Currently the only type of VDL Mode 2 handoff operational within LINK 2000+ is the aircraft initiated variant. Under this handoff procedure, the decision to initiate handoff resides purely within the aircraft. ICAO SARPs require the aircraft to initiate handoff when

- a) VHF signal quality is poor
- b) N2 downlink AVLC (Aviation VHF Link Control) re-tries have occurred for a single frame
- c) The TG2 inactivity timer expires
- d) Channel congestion is detected by expiry of the TM2 timer.

The first two events a) and b) are exercised during LINK 2000+ laboratory testing to verify that a stable link is maintained following handoff provoked by such an event. The latter two events are considered to be exceptional and are not discussed further here.

Neither ICAO SARPs nor ARINC 631 define what constitutes "poor VHF signal quality" and hence the exact criteria for initiating handoff under condition a) are established by implementers.

In general, AVLC re-tries are undesirable, and the avionics should seek wherever possible to initiate a handoff from a VGS before significant AVLC re-tries occur. In particular:

- a) If an AVLC link is operating under marginal conditions, the link may fail first either in the uplink or downlink directions. If the link fails first in the uplink direction (i.e. at the VGS), the aircraft will not recognise this immediately (assuming ground initiated handoff is not implemented), and handoff will only be initiated when the aircraft attempts to downlink (e.g. a message or keepalive), thus giving rise to a discontinuity in end-to-end coverage. In extremis this may cause a loss of IDRP, resulting in delay and overhead in order to re-establish end-to-end connectivity.
- b) Re-tries add to the overall channel loading, reducing capacity. Aircraft at the periphery of the coverage of a VGS represent a disproportionately high fraction of the load on the VGS due to geometrical considerations. If these aircraft are suffering

AVLC re-tries due to late initiation of handoff, overall capacity is likely to be adversely affected.

- c) Message transfer suffering from AVLC re-tries is likely to suffer increased end-to-end delays and as a consequence may exceed operational message timers.

There are certain conditions under which the AVLC link may be lost suddenly, such as an aircraft descending out of line-of-sight coverage from a connected VGS behind it. Under these conditions AVLC re-tries are unavoidable, and reliance is placed on handoff being initiated as a result of N2 re-tries (condition **b** above).

## FLIGHT TESTING EXPERIENCE

During flight tests it has been observed that bursts of high AVLC downlink re-try activity may occur over periods of up to several minutes. Here, a high AVLC re-try rate is regarded as being where the ratio of re-tried frames to successful frames transferred is greater than 20%. Furthermore, such re-try bursts may arise at Signal Quality Parameter (SQP) levels significantly greater than 0.

*Note: SQP levels mentioned in this document refer to the original SQP definition.*

The following figure illustrates the observed dependency of AVLC re-try rate with SQP level. It shows the number of AVLC re-tries arising from loss of downlink frames during sustained re-try episodes while performing a constant rate tuning test involving generation of one uplink and downlink CPDLC message every 10 seconds. This data was collected during flight trials conducted in the period July-September 2004.

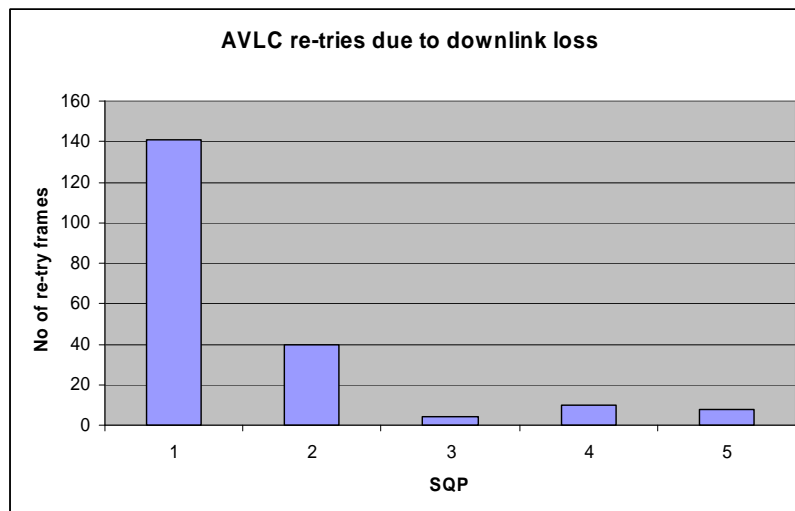

This figure illustrates that there is a substantially higher risk of AVLC re-try due to downlink loss at SQPs less than 2. The losses at SQP 0 are not shown because generally aircraft had initiated handoff to another VGS before recording significant AVLC re-tries at this level. However, had connections been maintained at SQP 0, the trend would suggest an even higher level of AVLC re-tries than at SQP 1.

The reasons for these re-tries remain under investigation. It has not proved possible to recreate these findings under laboratory conditions, and there is currently no evidence that these findings result from any defect or underperformance of the equipment involved.

The most important conclusion is that the risk of AVLC re-tries should be expected to increase progressively as SQP reduces, and may cause significant performance degradation at SQPs less than 2. Accordingly, wherever possible the air initiated handoff algorithm should be designed to handoff to another VGS before the aircraft reaches a scenario where there is a risk of significant AVLC re-tries.

In other words, attempting to maintain an AVLC link when SQP is 0 or 1 may lead to excessive AVLC re-tries which could be avoided if other VGSs with superior signals are available.

On the other hand, generating handoffs in rapid succession is also undesirable due to the associated activity at the VDL 8208 and possibly IDRPs levels.

It should be noted that SQP may rise and fall rapidly. Short term nulls in coverage have been observed with particular VGSs, sometimes reducing SQP to 0, probably due to installation effects on the antenna patterns. Handoff algorithms should aim to be robust to this type of behaviour.

## HANDOFF ALGORITHMS

It is not EUROCONTROL's intention to propose specific handoff algorithms for implementers, but to offer general guidance based on observations made during considerable validation flight testing conducted by EUROCONTROL.

Based on the above discussion, implementers should design their handoff algorithms recognising the following:

- a) Handoff algorithms should seek to avoid maintaining an AVLC link under conditions where there is a significantly increased risk of AVLC re-tries.
- b) The risk of AVLC re-tries appears to be significantly increased at SQPs less than 2.
- c) Handoff algorithms should avoid generating handoffs in rapid succession, under conditions of rapid changes in SQP and/or short term nulls from individual VGSs.

For example, it may be advantageous for the aircraft to take into account the long term trend of SQP for each VGS recorded in the Peer Entity Contact Table (PECT). The trend would require a high degree of smoothing to reduce the impact of rapid short term fluctuations. With such information available, handoff could be initiated from a station with falling SQP to one with rising SQP, whenever the SQP from the candidate VGS exceeds that of the current SQP by a pre-determined margin. When the current SQP falls below 2, the criteria may be relaxed, to initiate handoff to any station with superior SQP, giving precedence to a VGS whose SQP is increasing.

Additionally, the handoff algorithm may take account of additional information on the quality of the AVLC link, such as the AVLC re-try rate, or the level of error correction applied (not currently available outside of the VDR) which may complement SQP in determining when to initiate handoff.

## ***A.4 ANNEX – ATN ROUTING AMBIGUITY ASSOCIATED WITH VDL HANDOFF***

### **INTRODUCTION**

ICAO and AEEC standards incorporate the principle of make-before-break in the management of VDL links during handoff. This is implemented by means of the TG5 link overlap timer, which is started at establishment of the new link, and when TG5 expires, causes the old link to be silently disconnected. In the event that the new link malfunctions, TG5 is cancelled, causing the old link to be preserved.

Flight trials performed by the LINK 2000+ Programme have highlighted that under certain conditions, the overlap between old and new links during TG5 may lead to ambiguity of routing information within the ATN. In the most severe case, an ATN routing 'black-hole' may arise, where an ATN route is maintained, but which is incapable of reaching the aircraft.

This paper considers four scenarios:

- Scenario 1 represents the simplest case where handoff occurs between two VGS connected to the same ATN A/G Router. This does not give rise to any issues.
- Scenario 2 considers the case where a handoff occurs between two VGSs of the same provider, but connected to different ATN A/G Routers.
- Scenario 3 considers the case where a transition is made from one provider to another.
- Scenario 4 considers handoffs involving a change of frequency.

The purpose of this paper is to raise awareness of these ATN routing issues, and to promote a consensus among LIT stakeholders on appropriate resolutions.

### **SCENARIO 1 – HANDOFF BETWEEN VGSs CONNECTED TO SAME A/G ROUTER**

This is illustrated in Figure 1, and represents the simplest 'baseline' case. No ATN routing issues have been observed in this case.

During a normal handoff in this scenario, the following sequence of events occurs:

- The aircraft is connected via VGS A.
- SVC A connects the Air Router to the A/G Router, supporting an IDRP Adjacency between them.
- The aircraft performs a handoff to VGS B
- Upon establishment of the new link with VGS B, the TG5 timer maintains the old link, and the associated SVC A to the A/G Router.
- A new SVC B is established to the same A/G Router via the new VGS.

- Eventually, TG5 timer expires, and the old link and SVC A are disconnected.
- The original IDRP Adjacency between the Air Router and the A/G Router is maintained.

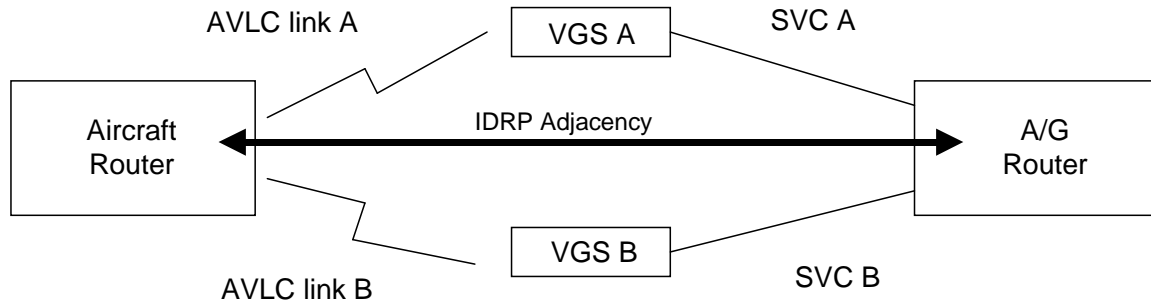

Fig 1: Handoff between VGSs connected to same A/G Router

Since only a single IDRP Adjacency over the Air-Ground link is involved, the selection between the two alternative SVCs to the aircraft is made by forwarding rules rather than by comparing the merit of different ATN Routes. The forwarding rules state that packets are sent over the connection most recently used, thus ensuring that following VDL Handoff, packets are transferred via the new VGS.

It should be noted that TG5 needs to be set sufficiently long on the ground to ensure that the new SVC B is established before timer TG5 expires. Otherwise, the IDRP Adjacency would be broken following the loss of SVC A.

## SCENARIO 2 - HANDOFF BETWEEN VGSs CONNECTED TO DIFFERENT A/G ROUTERS

This scenario, where the two VGSs are both from the same provider is illustrated in Figure 2. In this scenario, the normal sequence of events at handoff are:

- The aircraft is connected via VGS A, as before.
- SVC A supports an IDRP Adjacency with A/G Router A.
- The aircraft performs a handoff to VGS B.
- Upon establishment of the new link with VGS B, the TG5 timer maintains the old link, and the associated SVC A to the A/G Router A.
- A new SVC B is established, connecting the Air Router to the new A/G Router B.
- IDRP will attempt to establish a new Adjacency between the Air Router and A/G Router B.
- The old Adjacency to A/G Router A will be maintained until TG5 expires.
- Hence during the link overlap period, two IDRP Routes between the ground and the aircraft exist.

It is quite possible that both Routes will have equal merit, and in such an event, the Routers will need to make a decision on which route to use. It is clearly desirable that the Route via the new link should be selected by preference, since the reason for the handoff was most likely that the old link was compromised. However, no specific ATN requirements appear to exist to assert a preference for the ATN Route via the new VGS following handoff. Given two routes of equal merit, ISO IDRPs standards specify a selection based only on the order of addresses.

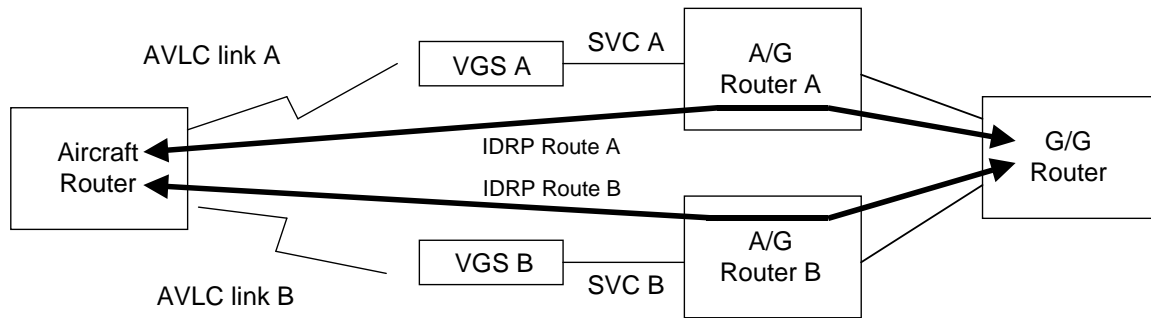

Fig 2: Handoff between VGSs connected to different A/G Routers

At the aircraft side, it would be possible to assert a local preference for the new route, since the aircraft is aware of the VDL handoff and that the route via the new VGS is the preferred one. However, this action is not currently required by ATN standards.

At the ground side, the selection between different ATN routes to the aircraft may well be made at a G/G Router which is not required to receive information on VDL handoffs. In the absence of special measures to ensure that the appropriate route to the aircraft is selected, it is possible that uplink to the aircraft may be transferred by means of the ATN Route via the old VGS.

These issues must be considered in the light of the difference between default TG5 values on the air and ground side. For an air initiated handoff, the aircraft's TG5 timer expires after 20 seconds (default value), after which the old link is silently disconnected at the aircraft, and the aircraft will no longer be reachable via the old link and hence the old ATN Route A. On the other hand, the default value of TG5 on the ground is 60 seconds. This implies that the old ATN Route A on the ground may continue to exist for a further 40 seconds after the aircraft has disconnected its old link. In other words, the old Route A has become a 'black-hole' route, which is incapable of delivering PDUs to the aircraft. Bearing in mind that the ED-120 requirement is to complete a round trip CPDLC transaction within 2 minutes, 40 seconds is judged to be an unacceptably long time to preserve a dysfunctional ATN Route.

It is believed that the longer default value of TG5 on the ground was specified in order to accommodate delays in establishing the new AVLC link at the aircraft due to re-transmissions of the XID\_HO\_RSP from the new VGS (the TG5 timer on the aircraft is started only on receipt of this frame). It may be argued that the IDRPs routing ambiguity could be partially mitigated by means of a somewhat closer alignment between TG5 timers on both ends of the link. However, this would not prevent selection of less appropriate ATN Routes on the ground via the old VGS prior to expiry of TG5. It is considered that the TG5 timer values should be set purely to achieve robust handoff behaviour, rather than to solve a routing issue elsewhere in the ATN stack.

Accordingly it is proposed that to resolve this issue:

- Avionics should assert a local preference for the IDRPs route via the new VGS, following a VDL handoff involving a change of A/G Router.

- ACSPs should implement special measures in their ground systems, to ensure that uplink PDUs are routed over the IDRPs route via the new VGS following a VDL handoff involving a change of A/G Router. (This is required by the LINK 2000+ Generic ACSP Requirements Document).

*Note: At the time of writing, the only LINK 2000+ ACSP within which handoff between A/G Routers may occur is ARINC. They have advised the LINK Integration Team that they have already incorporated measures to ensure that uplink PDUs are sent via the appropriate IDRPs route following such a handoff.*

### SCENARIO 3 – TRANSITION BETWEEN VDL SERVICE PROVIDERS

The scenario where an aircraft makes a transition between different VDL providers is in principle similar to the one illustrated in Figure 2, except that AVLC connections to a new provider will be established by means of XID\_LE exchanges rather than XID\_HOs. Furthermore, no TG5 procedures apply in such cases. Accordingly, the two links and associated ATN Routes via different Providers may persist for some time, depending on the aircraft's connection policy. Industry standards allow an aircraft to maintain connectivity with more than one service provider in accordance with airline preferences.

Consequently, in such cases, the uplink traffic may continue to be routed via the non-preferred provider until the link with the Provider is disconnected. Unlike Scenario 2, where the ACSP may implement measures within its own G/G Router to resolve the uplink routing ambiguity, no such opportunity exists in these cases.

Accordingly, when connections exist with more than one provider at the same time, avionics should implement measures to ensure that ATN traffic is routed via the preferred provider. This may be particularly important in the event that a connection to a new provider has occurred due to failing coverage from a previous provider.

Provided that any connection with the non-preferred provider is maintained only to support non-ATN applications, the recommended approach is to disconnect the SVC to the non-preferred provider as soon as an IDRPs adjacency has been established via the new provider, and uplink IDRPs UPDATE PDUs have been received on that adjacency conveying routes with security to the ground (prefixes 47002701/47002781).

### SCENARIO 4 – HANDOFFS INVOLVING FREQUENCY CHANGE

When a frequency change occurs during a handoff between VGS connected to the same A/G Router, no additional considerations apply beyond those discussed for Scenario 1. Provided TG5 maintains the old link beyond the time taken to establish the SVC on the new frequency, the IDRPs Adjacency is preserved. The forwarding rules then ensure that packets are transferred preferentially over the new link.

In the case where a handoff involving a frequency change coincides with a change in A/G Routers, the situation illustrated in Figure 2 still applies in principle. However, the aircraft now changes frequency before establishing the new link and so the old ATN Route immediately becomes a 'black-hole' route incapable of reaching the aircraft. Hence the problem highlighted under Scenario 2 becomes more severe in multi-frequency operation. In recognition of this, the multi-frequency protocols of ARINC 631-5 aim to prevent a change of ATN A/G Router at the same time as a change of frequency.

### CONCLUSIONS

Under various scenarios, ATN Routing Ambiguity may arise following VDL Handoff, leading either to use of an inappropriate Route to the aircraft, or else in the worst cases to maintenance of a 'black-hole' Route that is incapable of reaching the aircraft.

Measures to overcome these issues have been proposed as follows.

- Avionics should assert a local preference for the IDRP route via the new VGS, following a VDL handoff involving a change of A/G Router.
- ACSPs should implement special measures in their ground systems, to ensure that uplink PDUs are routed over the IDRP route via the new VGS following a VDL handoff involving a change of A/G Router. (This is required by the LINK 2000+ Generic ACSP Requirements Document).
- When connections exist with more than one provider at the same time, avionics should implement measures to ensure that ATN traffic is routed via the preferred provider, normally by disconnecting the SVC to the non-preferred provider as soon as an IDRP Adjacency has been established via the new provider and routes to the ground have been received.



© European Organisation for the Safety of Air Navigation (EUROCONTROL)  
December 2009

This document is published by EUROCONTROL for information purposes. It may be copied in whole or in part, provided that EUROCONTROL is mentioned as the source and it is not used for commercial purposes (i.e. for financial gain). The information in this document may not be modified without prior written permission from EUROCONTROL.

[www.eurocontrol.int](http://www.eurocontrol.int)